



Over voltage and over current protection IC

Description

AF4801A is an Over-Voltage-Protection (OVP) IC. The device will switch off internal MOSFET to disconnect VIN to OUT to protect load when any of input voltage, input current over the threshold. The Over temperature protection (OTP) function monitors chip temperature to protect the device.

Applications

- PND
- Tablet
- HD Player
- OTT
- Digital Cameras
- Digital Videos

Device Information



XX YY: part number

XXXXX.1: Wafer batch

Top view

Package	DFN8 (0203-0.75-0.50)
MOQ	3000 pcs

Features

- High voltage technology
- Maximum input voltage :30V
- Output power ON time :8ms(Typ)
- OVP threshold:Used Pin PROADJ Options
- OVP response time :<1us
- Output auto discharge
- Small Package:DFN8L (0203-0.75-0.50)

Typical Application

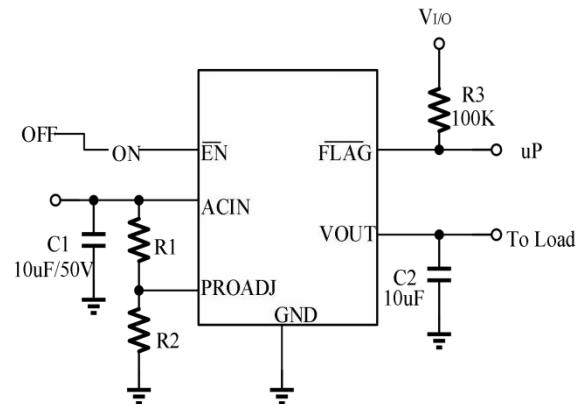

Functional Block Diagram

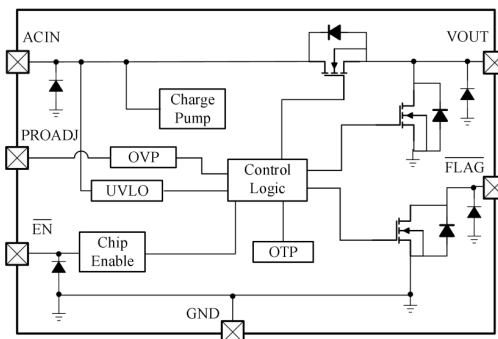



Pin Configuration

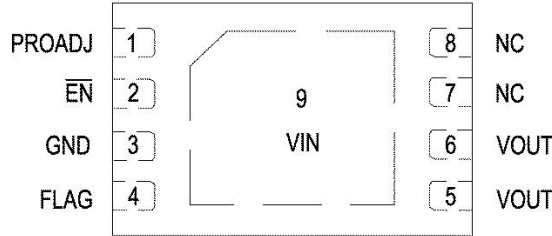

AF4801A

Pin configuration (Top view)

NO.	Symbol	Type	Description
1	PROADJ	INPUT	Over voltage options pin
2	\overline{EN}	INPUT	Enable pin. Active Low.
3	GND	GROUN D	Ground
4	FLAG	OUTPUT	Flag Pin. Open-Drain, Active low if any OVP, OTP occur.
5/6	VOUT	OUTPUT	Output pin. Connect to load.
7/8	NC		
9(Bottom pad)	VIN	POWER	Input pin. A 10uF low ESR ceramic capacitor or larger must be connected as close as to this pin. It is recommended to use 50V capacitor or according to application.

Absolute Maximum Ratings⁽¹⁾

(Unless otherwise specified, all voltage are with respect to GND, TA=25°C)

PARAMETER	SYMBOL	RATINGS	UNITS
Input voltage (ACIN pin)	V _{IN}	-0.3 ~ 30	V
Output voltage (VOUT pin)	V _{OUT}	-0.3 ~ 30	V
Junction temperature	T _J	150	°C
Storage temperature	T _{stg}	-55 ~ 150	°C
ESD Ratings	HBM	±3000	V
	MM	±200	V

(1). Stresses beyond those listed under absolute maximum ratings may cause permanent damage to the device. These are stress ratings only, and functional operation of the device at these or any other conditions beyond those indicated under recommended operating conditions is not implied. Exposure to absolute-maximum-rated conditions for extended periods my affect device reliability.

Recommend Operating Conditions

(Ta=25°C, unless otherwise noted)

Parameter	Symbol	Value	Unit
Input voltage	V _{IN}	3.5 ~ 30	V
Output current	I _{OUT}	3	A
Ambient operating temperature	T _{opr}	-40 ~ 85	°C

**✚ Electrical Characteristics**

(Ta=25°C, unless otherwise noted)

Parameter	Symbol	Test conditions	Min	Typ	Max	Unit
DC characteristics and Power-ON-Reset						
Input quiescent current	I _Q	V _{ACIN} =5V, I _{out} =0A		120	200	uA
IN-to-OUT ON resistance	R _{ON}	V _{ACIN} =4.5V, I _{out} =3A		40		mΩ
Output auto discharge resistance	R _{DISCHARGE}			500		Ω
Under voltage lock out threshold	UVLO	V _{ACIN} increasing from 0~3.5V		3.4		V
Under voltage lock out hysteresis	V _{HYS-UVLO}	V _{ACIN} decreasing from 3.5~0V		300		mV
Output power-on time	T _{ON}	V _{ACIN} =0 -> 5V to output ON	6	8	10	ms
EN Threshold Voltage	VENL				0.4	V
	VENH		1.2			V
EN to GND current	I _{EN}				2	uA
Input Over-Voltage-Protection (OVP)						
PROADJ threshold	V _{PROADJ}	V _{ACIN} increasing from 5~7V		1.21		V
PROADJ hysteresis	V _{HYS-PROADJ}	V _{ACIN} decreasing from 7~5V		70		mV
OVP active time	T _{OVP}	V _{ACIN} =5 -> 10V			1	us
OVP recovery time	T _{ON(OVP)}	V _{ACIN} =10 -> 5V to output ON	6	8	10	ms
Over-Temperature-Protection (OTP)						
OTP threshold				155		°C
OTP hysteresis				40		°C
Power Switch Body Diode						
Forward peak surge current	I _{FSM}	Pulse Width=10ms			15	A
		Pulse Width=20us			50	A

✚ The formula for over voltage:

$$OVP = 1.21 * \left(\frac{R1}{R2} + 1 \right)$$



Typical characteristic

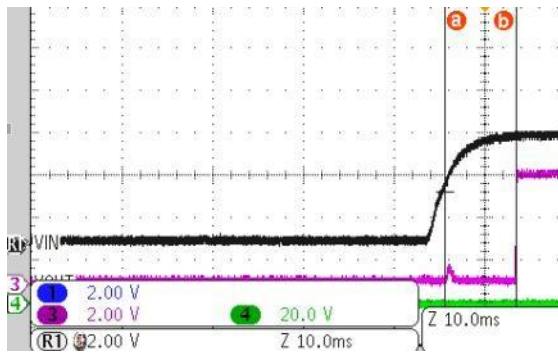

Power ON

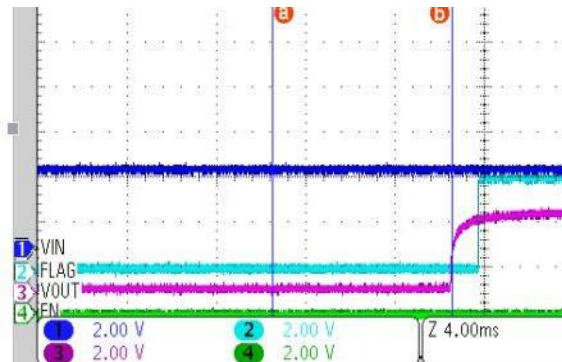

UVLO_H

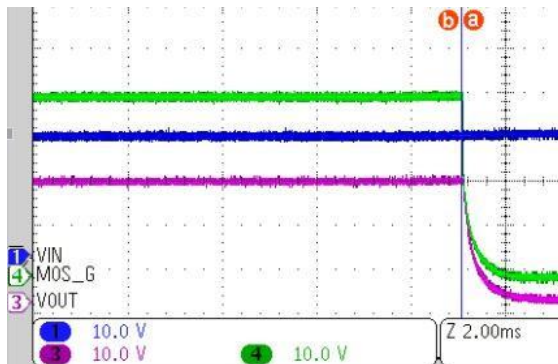

PROADJ_OVP

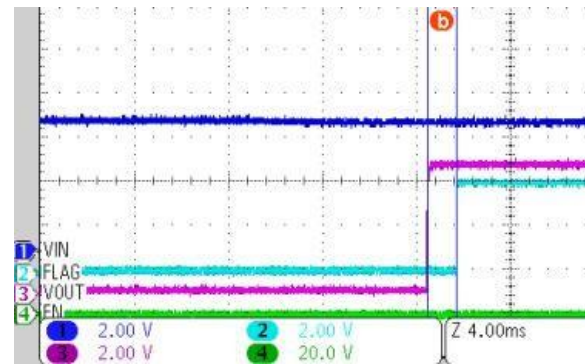

FLAG_DELAY

Temperature Stability

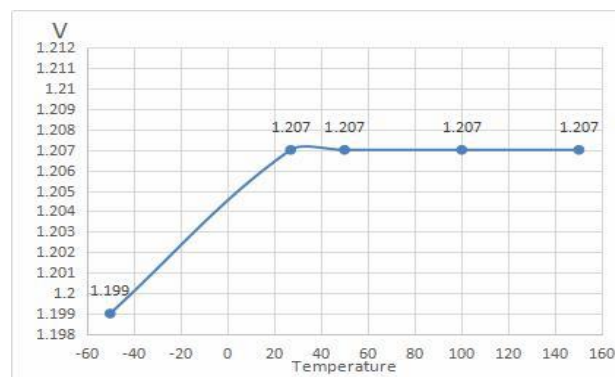

OVP threshold V-PROADJ & Temperature



Package Outline

DFN8L (0203-0.75-0.50)

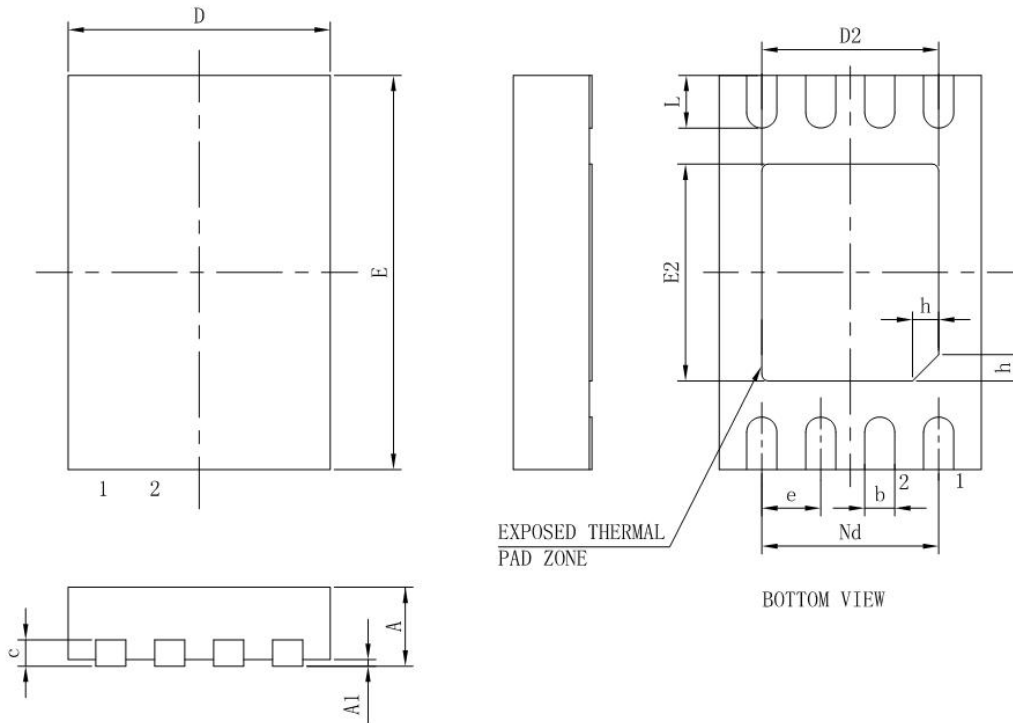

Package outline

UNIT:mm

Symbol	Min	Type	Max
A	0.70	0.75	0.80
A1	-	0.02	0.05
b	0.20	0.25	0.30
c	0.18	0.20	0.25
D	1.90	2.00	2.10
D2	1.40	1.50	1.60
E	2.90	3.00	3.10
E2	1.50	1.60	1.70
e	0.50BSC		
Nd	1.50BSC		
L	0.30	0.40	0.50
h	0.20	0.25	0.30



Tape and Reel

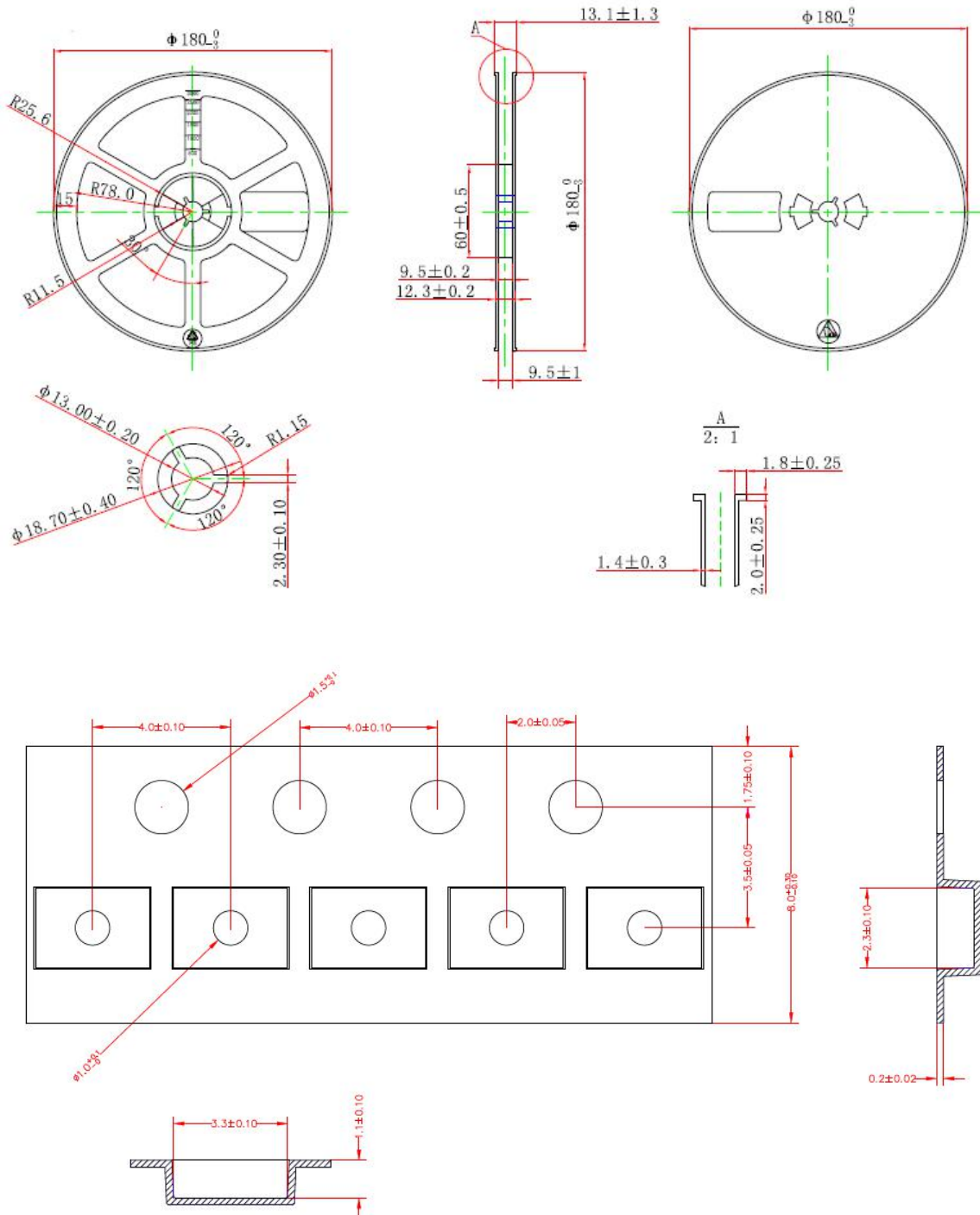



DISCLAIMER

AFSEMI RESERVES THE RIGHT TO MAKE CHANGES WITHOUT FURTHER NOTICE TO ANY PRODUCTS HEREIN TO IMPROVE RELIABILITY, FUNCTION OR DESIGN. AFSEMI DOES NOT ASSUME ANY LIABILITY ARISING OUT OF THE APPLICATION OR USE OF ANY PRODUCT OR CIRCUIT DESCRIBED HEREIN; NEITHER DOES IT CONVEY ANY LICIENCE UNDER ITS PATENT RIGHTS, NOR THE RIGHTS OF OTHERS.

THE GRAPHS PROVIDED IN THIS DOCUMENT ARE STATISTICAL SUMMARIES BASED ON A LIMITED NUMBER OF SAMPLES AND ARE PROVIDED FOR INFORMATIONAL PURPOSE ONLY. THE PERFORMANCE CHARACTERISTICS LISTED IN THEM ARE NOT TESTED OR GUARANTEED. IN SOME GRAPHS, THE DATA PRESENTED MAY BE OUTSIDE THE SPECIFIED OPERATING RANGE (E.G. OUTSIDE SPECIFIED POWER SUPPLY RANGE) AND THEREFORE OUTSIDE THE WARRANTED RANGE.